

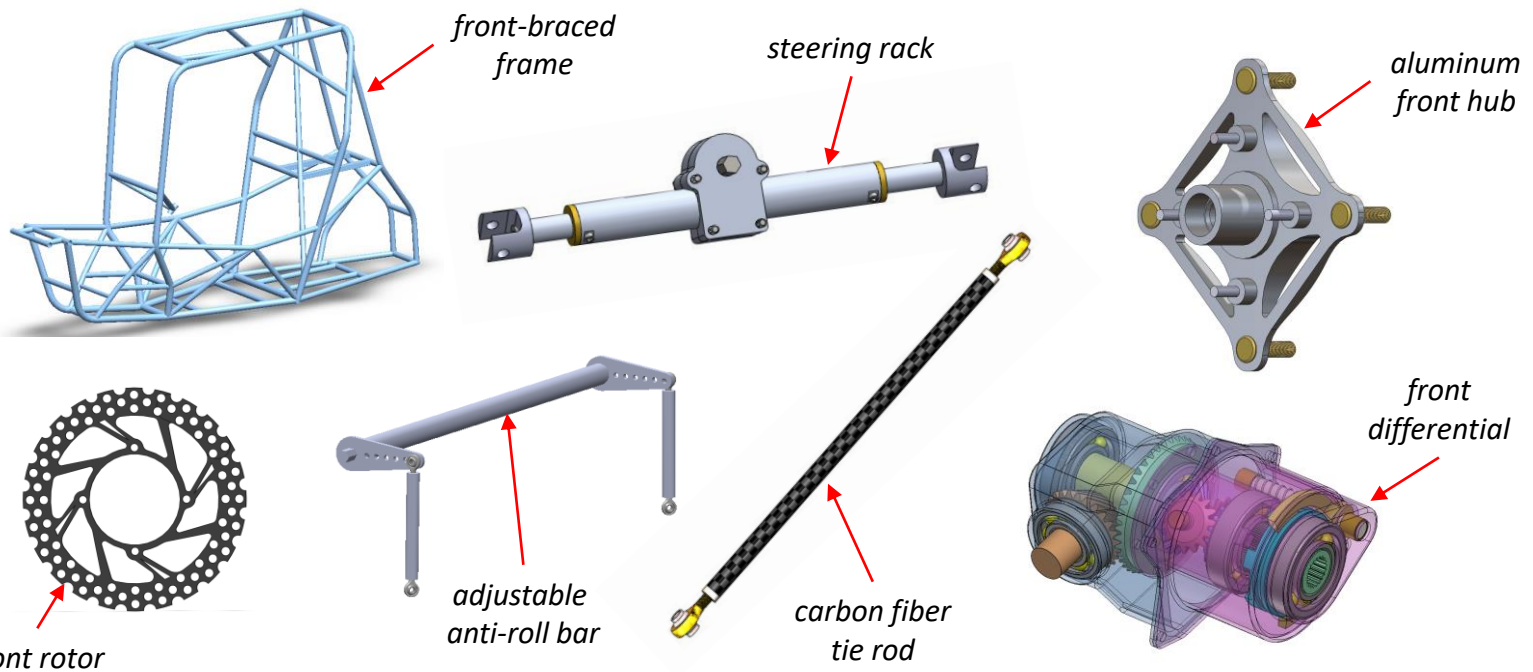

TEAM HIGHLIGHTS

After over four months of design, the team had our internal critical design review in late August. Each component designer presented on what they've been working on and were able to get feedback so they can make any necessary tweaks before we freeze designs.

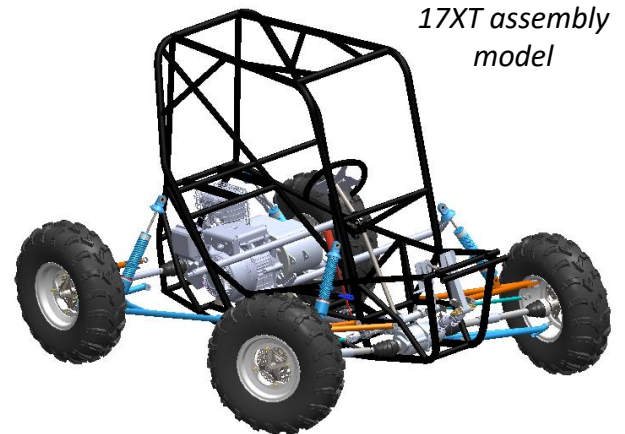

After our design freeze at the end of August, each component and test rig designer will be completing a design document covering every detail from load calculations to analysis methods. This is part of a huge push we've been doing towards better documentation practices to preserve knowledge from year-to-year.





TIMELINE

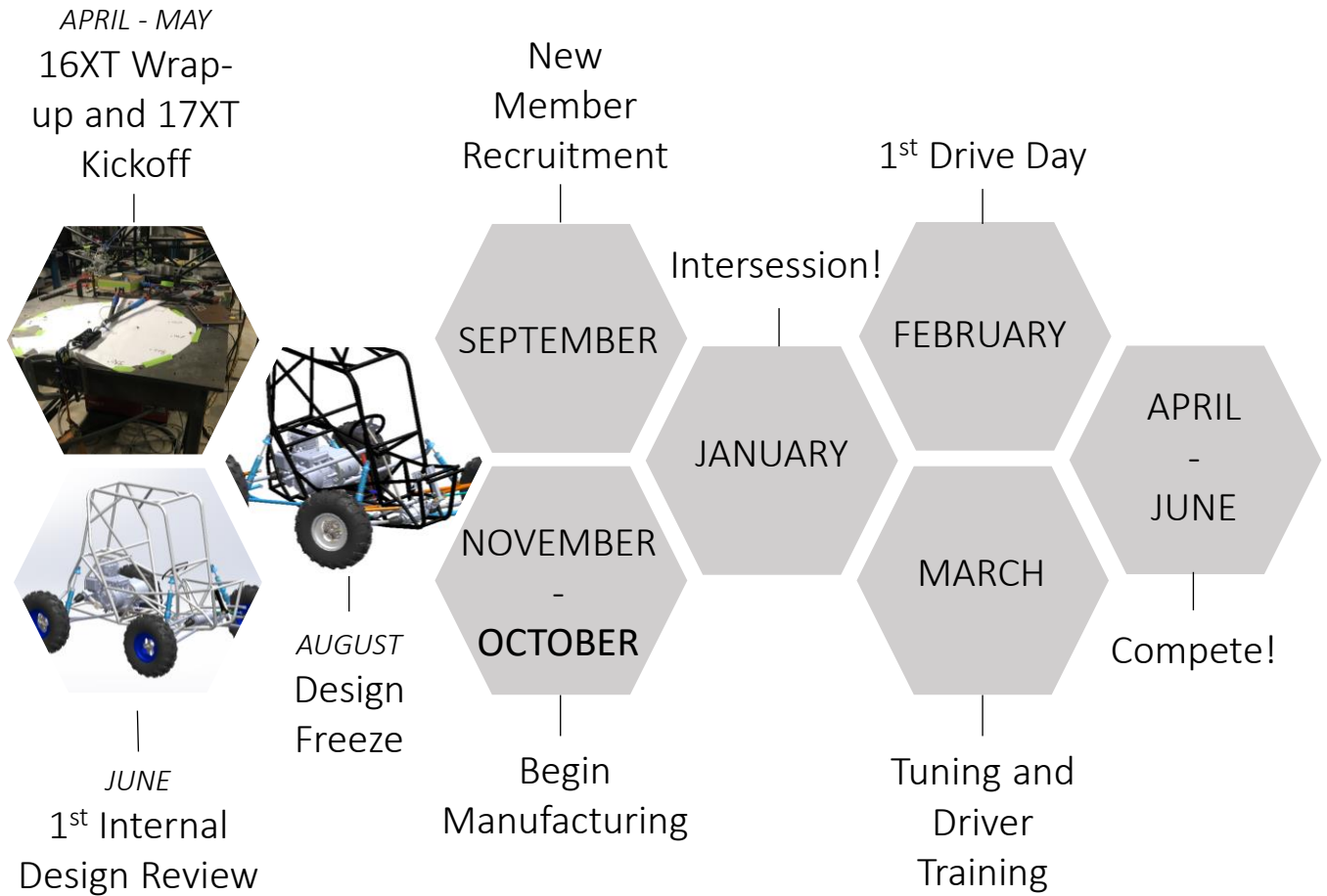

ON THE HORIZON

Hopkins announced in early August that their original plan to have students back on campus for the fall semester would no longer be possible and students will be doing remote learning at least through this semester. Without access to our machine shop, we've adjusted our fall plan to focus on design and analysis projects that we can work on virtually.

This semester is giving us a unique opportunity: the design of our 2021 vehicle is mostly completed, but since we aren't going to be manufacturing we have a ton of manpower that can be focused on longer-term projects that we don't normally have the bandwidth to work on.

We'll have more details in our next team update on what our fall plan is!



SPONSOR SPOTLIGHT

We'd like to thank Danko Arlington, who has been sponsoring the casting of our CVT backplate since 2013! Every year Danko invites team members to tour the shop facilities and watch the casting process from 3D printing to post-casting analysis.



Not only does Danko manufacture our backplate, but their engineers also give us design feedback in order to ensure the part is optimized for the casting process. We're excited to continue working with Danko in the future!

TEAM MEMBER SPOTLIGHT



Meet Ari! She's a sophomore mechanical engineering student from Philadelphia, PA. She joined the team during her freshman year, and worked on manufacturing linkages and uprights, along with heading a project to repair a previous vehicle.

This year she is designing the team's first carbon fiber tie rods and the clevises that link them to the steering rack, along with a validation rig for the uprights.

When she's not working on the car, Ari can be found working on sets and lighting for several campus theatre groups!

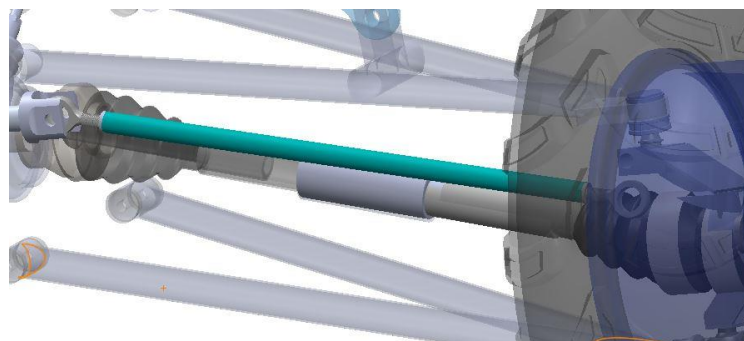



BLUE JAY
RACING

AUGUST 2020

THANK YOU FOR YOUR SUPPORT!

TEXTRON



JOHNS HOPKINS
WHITING SCHOOL
of ENGINEERING

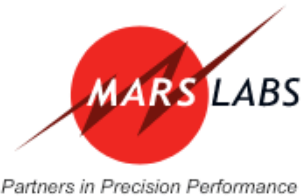

thyssenkrupp



WSE
MANUFACTURING



BASS
MACHINING



TOP FLIGHT
AUTOMOTIVE

Ramsey Products
CORPORATION

Hilliard



SOLIDWORKS



carparts.com™

KISSsoft